

# CHD



DOWNLOAD  
THE BROCHURE



WATCH THE  
VIDEO

## CHAIN TRENCHERS

**category**

2.5 - 15 TON



Midi Exc.



Exc.



Backhoe

**models**

CHD 90SB | CHD 120SB | CHD 90B  
CHD 120B | CHD 150B

### FOR EXCAVATOR BOOMS

CHD chain trenchers for excavator booms are designed for set-section trenching on natural soils. The discharge screw on the right-hand side and the trench clearing device make sure the trench is always kept clean. Models 90S B and 120S B are recommended for soft soils.

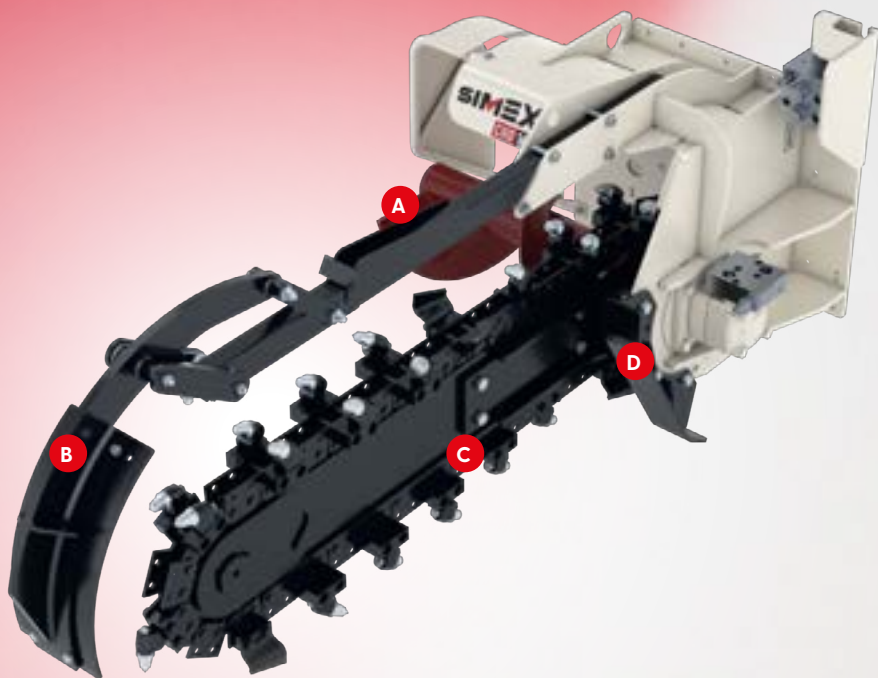

- A** Material discharge screw on right-hand side.
- B** Rear scraper.
- C** Chain is available with hoe blades for soft soils or hoe blades with teeth for mixed soils.
- D** The support slide provides maximum stability at any trenching depth.

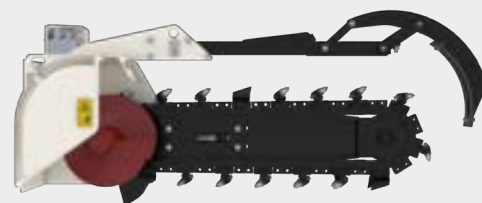
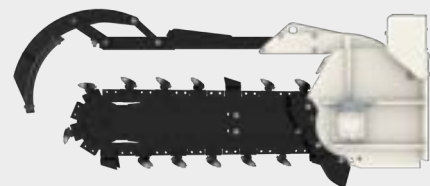
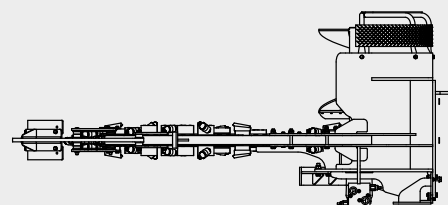
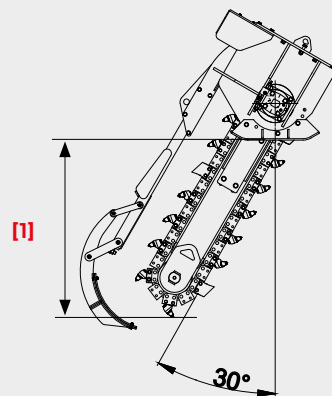

### SOFT SOILS

### MIXED SOILS

TECHNICAL DATA	SOFT SOILS		MIXED SOILS			
		CHD 90 S B	CHD 120 S B	CHD 90B	CHD 120B	CHD 150B
<b>Maximum trench depth [1]</b>	mm	900	1200	900	1200	1500
	inch	35	47	35	47	59
<b>Standard trench width</b>	mm	150	150	150	150	150
	inch	6	6	6	6	6
<b>Optional trench width</b>	mm	100 - 200	100 - 200	200 - 250	200 - 250	200
	inch	4 - 8	4 - 8	8 - 10	8 - 10	8
<b>Scraper</b>		mechanical with spring		mechanical with spring		
<b>Operating weight (*) (**)</b>	kg	260	425	525	590	640
	lbs	570	936	1150	1300	1410
<b>Required oil flow</b>	l/min	35 - 95	60 - 115	60 - 120	70 - 140	90 - 160
	gpm	9 - 25	16 - 30	16 - 32	18 - 37	24 - 42
<b>Maximum oil pressure</b>	bar	240	240	250	250	250
	psi	3500	3500	3625	3625	3625
<b>Recommended excavator weight</b>	ton	2.5 - 4.5	4.5 - 8	7 - 15	8 - 15	8 - 15
	lbs	5500 - 9900	9900 - 17640	15400 - 33000	17600 - 33000	17600 - 33000

\* The installer is responsible for ensuring that the equipment meets the excavator's specifications and weight requirement. \*\* Without mounting bracket. Simex does not accept responsibility or liability for the information provided. Technical modifications may vary without prior notice.