

CT



DOWNLOAD
THE BROCHURE



WATCH
THE VIDEO

SIMEX
• patented •

VIBRATING WHEEL COMPACTORS

category

5 - 12 TON



Midi Exc.



Exc.

models

CT 2.8B | CT 3.8B



Designed for compacting trench bottoms, Simex CT vibrating wheel compactors guarantee a solid, even and well-compacted bottom that ensures maximum road safety and will not give way under the weight of farming or other heavy vehicles.





360° HYDRAULIC ROTATION (OPTIONAL):

activated from the cabin, allows compaction in any position, even in the most difficult-to-reach spots.

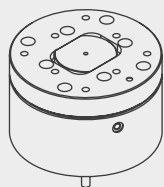

135° MECHANICAL ROTATION WITH HYDRAULIC LOCKING (OPTIONAL):

Does not require additional hydraulic control.

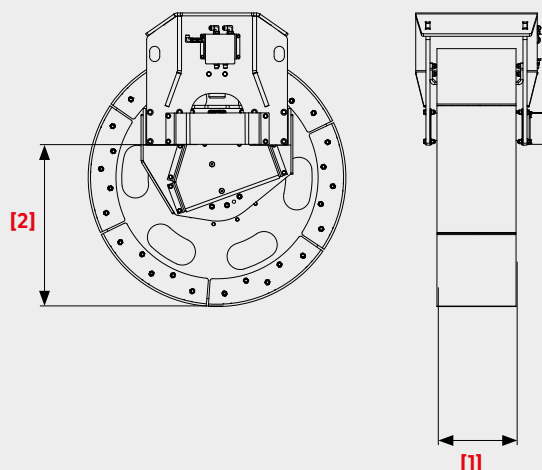

B Wheel width can be adjusted via bolted segments that are easily changed on site.

C Perfect insulation from prime mover, thanks to the reverse-rotation vibrating twin shaft positioned at centre of the wheel.



SEGMENTED WHEEL

In order to adapt to various types of section trenching, the CT vibrating compactor base wheel is fitted with bolted segments, easily changed on site.

Available widths: 50 - 75 - 100 - 150 - 200 - 250 - 300 - 350 - 400 mm.

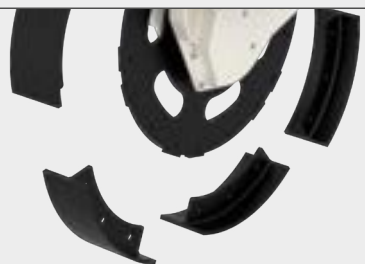

TECHNICAL DATA		CT 2.8 B	CT 3.8 B
Recommended excavator weight (*)	ton	5 - 9	7 - 12
	lbs	11000 - 20000	15400 - 26400
BASE WHEEL			
Width of bolted segments [1]	mm	150 - 200 - 250 - 300 - 350 - 400	150 - 200 - 250 - 300 - 350 - 400
	inch	6 - 8 - 10 - 12 - 14 - 16	6 - 8 - 10 - 12 - 14 - 16
Working depth [2]	mm	0 - 700	0 - 800
	inch	0 - 28	0 - 32
SPECIAL SECTORS			
Width of bolted segments (**)	mm	50 - 75 - 100	50 - 75 - 100
	inch	2 - 3 - 4	2 - 3 - 4
Working depth	mm	0 - 350	0 - 465
	inch	0 - 14	0 - 18
Vibration frequency	Hz	30 - 40	30 - 40
Max. vertical force	kN	42	42
	lbf	9400	9400
Operating weight (***)	kg	530 - 585	750 - 800
	lbs	1160 - 1300	1650 - 1760
Required oil flow	l/min	40 - 60	40 - 60
	gpm	11 - 16	11 - 16
Maximum oil pressure	bar	220	220
	psi	3200	3200

* The installer is responsible for ensuring that the equipment meets the prime mover's specifications and weight requirement. ** Widths other than those listed are available on request. *** Without mounting bracket. Simex does not accept responsibility or liability for the information provided. Technical modifications may vary without prior notice.